

**TEAC DV-28S-V93
DVD-ROM DRIVE**

HARDWARE SPECIFICATION

Rev. A

19 sheets in Total

TABLE OF CONTENTS

Title	Page
1. SCOPE	1
2. OUTLINE	1
3. CONSTRUCTION	2
3.1 External Construction	2
3.2 Installation	4
4. DISC SPECIFICATION	5
4.1 Applicable Disc Format	5
4.2 Rotational Speed	5
4.3 Data Capacity	6
5. PERFORMANCE	7
5.1 Operating Performance	7
5.2 Acoustic Noise	7
6. ENVIRONMENTAL CONDITIONS	8
7. RELIABILITY	9
8. SAFETY AND EMC STANDARDS	9
9. FRONT INDICATOR	9
10. INTERFACE CONNECTOR	10
11. POWER INTERFACE	11
12. SERIAL ATA HARDWARE INTERFACE	12
12.1 Outline	12
12.2 Electrical Characteristics	12
12.3 COMMAND SET	12
12.3.1 ATA COMMAND	12
12.3.2 ATAPI COMMAND	13
13. POWER MANAGEMENT SPECIFICATION	14
13.1 Power Management Modes	14
13.1.1 Transition in power management mode	14
13.2 Active Mode	15
13.3 Idle Mode	15
13.4 Standby Mode	16
13.5 Sleep Mode	16
13.5.1 Tray ejection/insertion in the sleep mode	16
14. OTHERS	16
14.1 Using the Lens Cleaner	16
14.2 RoHS Compliance	16
14.3 Safety of Laser Products	17

1. SCOPE

This is hardware specification of the TEAC DV-28S-V93 built-in type DVD-ROM drive (hereinafter referred to as drive). As for the software specification, refer to "DV-28S-V Software Specification".

2. OUTLINE

The outline of this drive is given in Table 2-1.

(Table 2-1) Outline of the specification

Model name	DV-28S-V93	
TEAC P/N	1977192V-93	
Applicable safety and EMC standards	UL, CSA, TÜV, CE	
Application rate	1.5Gbps	
Average access time	130msec (CD-ROM)/140msec (DVD-ROM), average by TEAC standards	
Disc speed (24x CAV speed mode)	5,090min ⁻¹ (Approx)	
Host interface	Serial ATA	
Power source	+5VDC	
Starting time	19sec max	
Readable discs	CD	CD-DA CD-ROM CD-R, CD-RW
	DVD	DVD-ROM DVD-R, DVD-R DL, DVD-RW, DVD+R, DVD+R DL DVD+RW, DVD-RAM
Applicable format	CD	CD-DA CD-ROM (Mode1, Mode2) CD-ROM XA Mode2 (Form1, Form2) Photo CD (Single/Multi-session) CD-i, Video-CD, CD-Extra (CD-Plus) CD-Text
	DVD	DVD-ROM DVD-Video DVD-R (Single/Multi-border) DVD-R DL (Single/Multi-border) DVD-RW (Single/Multi-border) DVD+R (Single/Multi-session) DVD+R DL (Single/Multi-session) DVD+RW (Single/Multi-session) DVD-RAM (4.7GB, 2.6GB)
Front bezel	Black	
Eject button	Black	
Access indicator	Green	
Laser class	Class 1 laser product	
RoHS directive	Complies with	

3. CONSTRUCTION

3.1 External Construction

- (1) Dimensions
 - (a) Height : 12.7mm (excluding the front bezel)
 - (b) Width : 128mm (excluding the front bezel)
 - (c) Depth : 129.4mm (excluding the eject button)
- (2) Mass : 176g or less
- (3) Disc clamp system : Ball clamp
- (4) Loading : Manual loading using the tray
- (5) Ejection
 - (a) Manual eject using the eject button
 - (b) Automatically eject using the command
 - (c) Eject distance : 10mm or more
- (6) External view : Refer to Fig. 3.1-1.

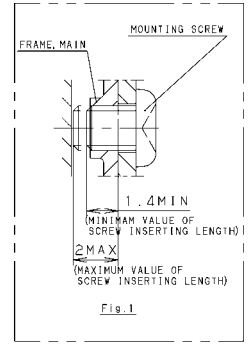
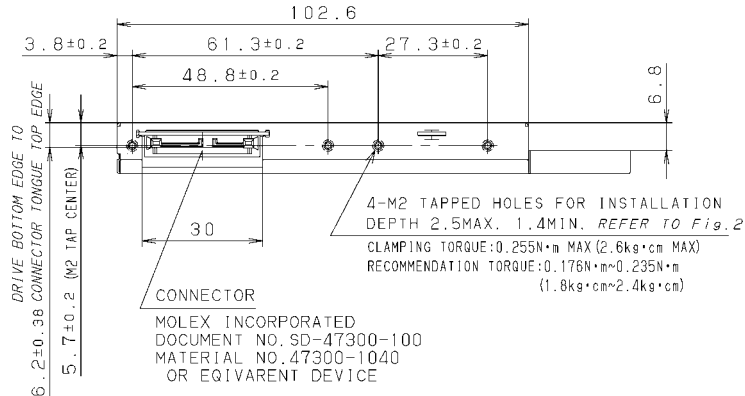
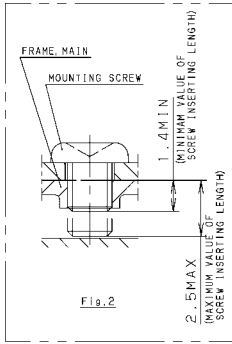

2- $M2$ TAPPED HOLES FOR INSTALLATION.
DEPTH 2.5MAX. 1.4MIN. REFER TO Fig. 2
CLAMPING TORQUE: 0.255N·m MAX (2.6kg·cm MAX)
RECOMMENDATION TORQUE: 0.176N·m~0.235N·m
(1.8kg·cm~2.4kg·cm)

CONNECTOR
SLIMLINE HOST
RECEPTACLE CONNECTOR

4- $M2$ TAPPED HOLES FOR INSTALLATION.
DEPTH 2.0MAX. 1.4MIN.
(LEFT SIDE X1, RIGHT SIDE X3) REFER TO Fig. 1
CLAMPING TORQUE: 0.255N·m MAX (2.6kg·cm MAX)
RECOMMENDATION TORQUE: 0.176N·m~0.235N·m
(1.8kg·cm~2.4kg·cm)

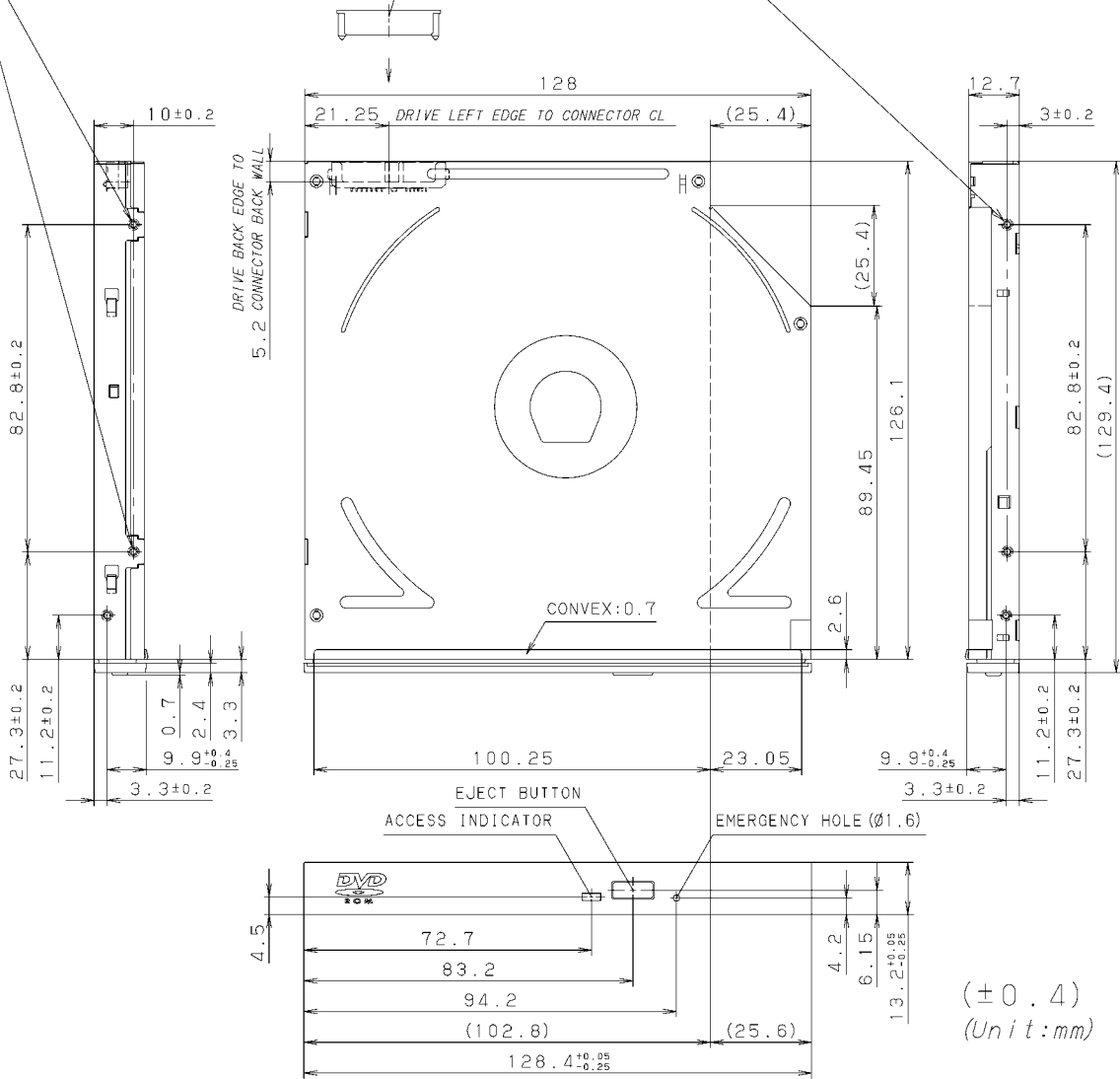

(Fig. 3.1-1) External view of the drive

3.2 Installation

- (1) Installation direction : Refer to Fig. 3.2-1
- (2) Tilt : Refer to Fig. 3.2-1 below.
- (3) Installation method : The fixing holes in the side of the unit are used.
Separate discussions and arrangements are required when the installation holes are not used.

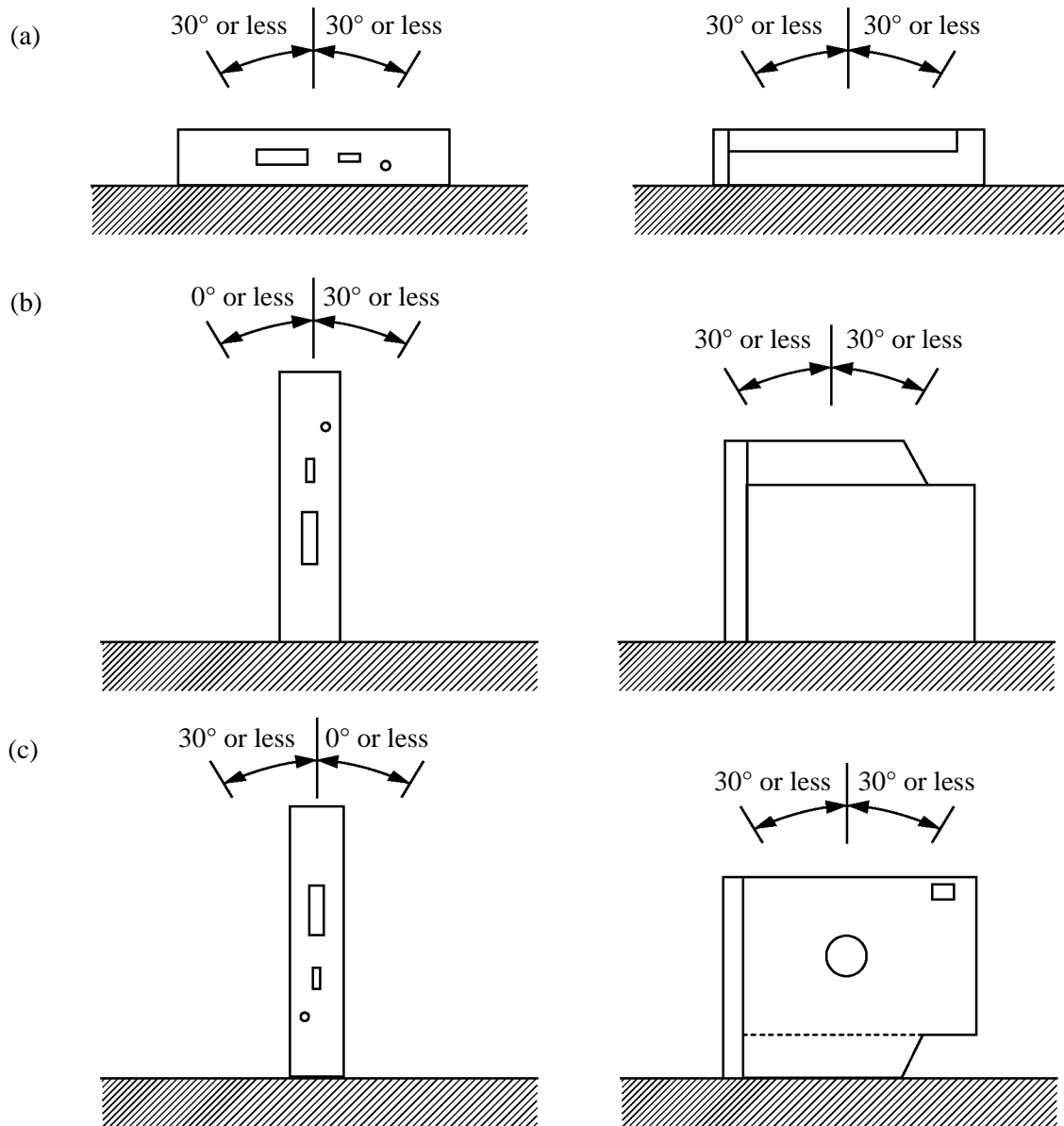

(Fig. 3.2-1) Tilt of the drive

4. DISC SPECIFICATION

4.1 Applicable Disc Format

(Table 4.1-1) Applicable disc format

CD	CD-DA CD-ROM (Mode1, Mode2) CD-ROM XA Mode2 (Form1, Form2) Photo CD (Single/Multi-session) CD-i Video-CD CD-Extra (CD-Plus) CD-Text
DVD	DVD-ROM DVD-Video DVD-R (Single/Multi-border) DVD-R DL (Single/Multi-border) DVD-RW(Single/Multi-border) DVD+R (Single/Multi-session) DVD+R DL (Single/Multi-session) DVD+RW (Single/Multi-session) DVD-RAM (4.7GB, 2.6GB)

4.2 Rotational Speed

Refer to Table 4.2-1 for the rotational speed.

(Table 4.2-1) Rotational speed

Operation/Disc format	Read speed/Disc speed
Idle mode (DVD)	4x CAV 2,297rpm
Idle mode (CD)	10x CAV 2,140rpm
Read (DVD-ROM)	8x CAV 4,594rpm
Read (DVD-Video)	4x CAV 2,297rpm
Read (CD-ROM Model)	24x CAV 5,137rpm
Read (CD-ROM Mode2form2)	20x CAV 4,280rpm
Read (CD-DA)	20x CAV 4,280rpm
Play Audio	4x CLV 856 - 1,984rpm
Read (Mixed, CD-ROM Model and Mode2form2 or CD-DA)	20x CAV 4,280rpm
Read (Mixed, DVD-ROM and DVD-Video)	8x CAV 4,594rpm
Read (CD-RW)	24x CAV 5,137rpm
Read (DVD-R, DVD-RW, DVD+R, DVD+RW)	8x CAV 4,594rpm
Read (DVD-R DL, DVD+R DL)	6x CAV 3,446rpm
Read (DVD-RAM, 4.7GB)	5x CAV 3,246rpm
Read (DVD-RAM, 2.6GB)	2.5x CAV 1,626rpm

4.3 Data Capacity

- 650MB/700MB : CD-ROM Mode1
: CD-ROM XA Mode2 Form1
- 738MB/795MB : CD-ROM XA Mode2 Form2
- 74min/79min : CD-DA
- 4.7GB/side : DVD-ROM, DVD-Video, DVD-R, DVD-RW, DVD-RAM, DVD+R,
DVD+RW
- 8.5GB/side : DVD-ROM, DVD-Video, DVD-R, DVD+R
- 2.6GB/side : DVD-RAM

5. PERFORMANCE

5.1 Operating Performance

- (1) Average random access time: 130msec average (CD-ROM, 24x), 140msec average (DVD-ROM, 8x)
- (2) Disc speed : Refer to 4.2.
- (3) Data transfer rate
 - (a) Read sustained : 1,545 to 3,600kB/sec (CD-ROM model)
4,469 to 10,816kB/sec (DVD-ROM)
 - (b) Programmed I/O : 16.7MB/sec max (Mode 0 to 4)
 - (c) Multi-word DMA : 16.7MB/sec max (Mode 0 to 2)
 - (d) Ultra DMA : 33.3MB/sec max
- (4) Starting time
 - (a) When power is switched on/when disc is loaded
: 19sec max (excluding the multi-session CD)
 - (b) Return time from the standby mode
: 4sec or less
- (5) Data buffer capacity : 198KB

5.2 Acoustic Noise

- (1) Operating : 45dBA or less (during seek/read/Active/Idle, distance 0.5m)
- (2) Ejecting : 65dBA typ (distance 0.5m)
- (3) Others : 35dBA or less (distance 0.5m)

6. ENVIRONMENTAL CONDITIONS

The environmental conditions as specified here do not include the environmental conditions of the disc. The environmental conditions of the disc should follow the specifications of the applicable disc.

- (1) Ambient temperature
 - (a) During operation : 5 to 55°C (Surface temperature on the top cover; 5 to 60°C)
 - (b) During non-operation : -20 to 60°C
 - (c) During transportation (packaged) : -40 to 65°C
- (2) Temperature gradient
 - (a) During operation : 11°C/hour or less (noncondensing)
 - (b) During non-operation/transportation : 20°C/hour or less (noncondensing)
- (3) Relative humidity
 - (a) During operation : 8 to 80% (noncondensing)
provided that the maximum wet-bulb temperature is 29.4°C or less.
 - (b) During non-operation/transportation : 5 to 95% (noncondensing)
provided that the maximum wet-bulb temperature is 29.4°C or less.
 - (c) During transportation (packaged) : 5 to 95% (noncondensing)
provided that the maximum wet-bulb temperature is 29.4°C or less.
- (4) Vibrations
 - (a) During operation:

When installed horizontally: 2.9m/s² (0.3G) or less
 When installed vertically : 1.96m/s² (0.2G) or less
 provided that the sweep frequency is 5 to 500Hz and sweep rate, 1oct/min.
 excepting recording mode.
 - (b) Transportation (packaged) : 19.6m/s² (2G) or less provided that the sweep frequency is 5 to 500Hz and sweep rate, 1oct/min.
- (5) Shock
 - (a) During operation (free from malfunction)

When installed horizontally: 68.6m/s² (7G) or less (half-sine shock pulse; 11msec, intervals; 10sec)
 When installed vertically : 49m/s² (5G) or less (half-sine shock pulse; 11msec, intervals; 10sec)
 excepting recording mode and CD-DA play mode.
 - (b) During operation (while the CD-DA is playing) : 19.6m/s² (2G) or less (half-sine shock pulse; 11msec, intervals; 10sec)
 - (c) During non-operation/transportation

: 588m/s² (60G) or less (half-sine shock pulse; 11msec)
 1,960m/s² (200G) or less (half-sine shock pulse; 2msec)
 However, tray ejection is allowed.
- (6) Dust : office environment
- (7) Cooling : natural air cooling

7. RELIABILITY

- (1) Mean time between failures (MTBF)
 - : 60,000POH or more (the frequency of use should be 10% at normal temperature and humidity)
- (2) Mean time to repair (MTTR) : 30minutes
- (3) Loading/ejecting life : 10,000times or more
- (4) Power ON/OFF life : 60,000 times or more
- (5) Laser diode life : MTTF 9,000 hours (Duty 50% pulse 83mW, 60°C)
- (6) Seeking life : 2×10^6 times or more (random access, 25°C, duty; 20% or less)
- (7) Error rate
 - (a) Read error rate
 - DVD : Once per 10^{12} bits or less
 - CD : Mode1 and Mode2 (Form1) : Once per 10^{12} bits or less
 - Mode2 (Form2) and CDDA : Once per 10^9 bits or less
 - (b) Seek error rate : Once per 10^6 seeks or less
- (8) Self-diagnosis
 - (a) When power is switched ON: Various controllers, ROM, RAM, buffer, ECC circuit, etc.
 - (b) When disc is inserted : Servo circuit, signal processors, etc.

8. SAFETY AND EMC STANDARDS

The drive complies with the following standards.

- (1) Safety standards
 - UL, CSA, TÜV, CE
- (2) EMC standards
 - CE

9. FRONT INDICATOR

- (1) Location : Refer to Fig. 3.1-1.
- (2) Color : Green
- (3) Lighting conditions
 - (a) Continuous on
 - During seek
 - Transfer of the read data to the host is under way.
 - (b) Flashing with a period of 3 second (Duty 50%)
 - During write
 - While audio is being played
 - (c) Flashing with a period of 1 second (Duty 50%)
 - From POR or tray loading to the end of TOC read (when the disc is present)
 - From POR or tray loading to the end of detecting the disc (when the disc is not present). If an error which is considered to arise from the disc occurs, flashing continues until the disc is ejected. If an error which seems to rest with the drive's hardware, flashing continues until the power is switched OFF.

10. INTERFACE CONNECTOR

- (1) Connector on the drive : MOLEX 47300-1040 or equivalent
- (2) Applicable connector on the host : MOLEX 47300-2010 or equivalent
- (3) Pin assignment : Refer to Table 10-1, Fig. 10-1.

(Table 10-1) Interface connector pin assignment

NAME	TYPE	DESCRIPTION
S1	GND	
S2	A+	Differential Signal Pair A
S3	A-	
S4	GND	
S5	B-	Differential Signal Pair B
S6	B+	
S7	GND	
P1	DP	Device Present
P2	+5V	
P3		
P4	MD	Manufacturing Diagnostic
P5	GND	
P6		

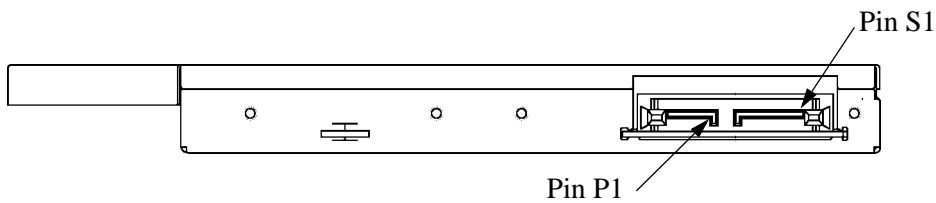

(Fig. 10-1) Interface connector assignment

11. POWER INTERFACE

The following specifications apply to the interface connector terminals of the drive. The power should be supplied from a power supply unit with reinforced insulation or double insulation.

- (1) Allowable supply voltage range : +5VDC \pm 5% (4.75 to 5.25V)
There should be no abnormal operations by DC +5V \pm 10%.
- (2) Allowable ripple voltage : 100mVp-p or less, 50 to 20MHz (including the spike noise)
- (3) Current consumption : Refer to Table 11-1.

(Table 11-1) Current consumption

Mode	Average current max (A)	Peak current max (A)
Standby/Sleep	0.05	—
Active	0.7	—
Random access (Duty 100%)	1.2	1.5
During starting/seek	—	1.5
During eject	—	1.2

Remarks:

1. The supply voltage should be 5V+5%.
2. For each of the sleep, standby, and active modes, refer to "**13. POWER MANAGEMENT SPECIFICATION**".
3. Does not include pulse-like current below 1msec.

12. SERIAL ATA HARDWARE INTERFACE

12.1 Outline

(1) Applicable standard

Serial ATA International Organization : Serial ATA Revision 2.6

ANSI standard : T13/1532D (ATA-7)

SFFC : SFF-8020i Rev. 2.6 and SFF-8090v6

12.2 Electrical Characteristics

Refer to Serial ATA Revision 2.6.

12.3 COMMAND SET

12.3.1 ATA COMMAND

Refer to table 12.3.1-1.

(Table 12.3.1-1) ATA COMMAND

CODE	COMMAND
08	ATAPI SOFT RESET
E5	CHECK POWER MODE
90	EXECUTE DRIVE DIAGNOSTIC
E1	IDLE IMMEDIATE
00	NOP
A0	ATAPI PKT.
A1	ATAPI IDENTIFY DEVICE
EF	SET FEATURE
E6	SLEEP
E0	STANDBY IMMEDIATE
A2	SERVICE

12.3.2 ATAPI COMMAND

Refer to table 12.3.2-1.

(Table 12.3.2-1) ATAPI COMMAND

CODE	COMMAND
12	INQUIRY
55	MODE SELECT (10)
5A	MODE SENSE (10)
4B	PAUSE/RESUME
45	PLAY AUDIO (10)
A5	PLAY AUDIO (12)
47	PLAY AUDIO MSF
49	PLAY TRACK RELATIVE (10)
A9	PLAY TRACK RELATIVE (12)
1E	PREVENT/ALLOW MEDIUM REMOVAL
28	READ (10)
A8	READ (12)
25	READ CD/DVD CAPACITY
BE	READ CD
B9	READ CD MSF
44	REEAD HEADER
42	READ SUB-CHANNEL
43	READ TOC
03	REQUEST SENSE
01	REZERO UNIT
2B	SEEK
BB	SET CD-ROM SPEED
4E	STOP PLAY/SCAN
1B	START STOP UNIT
00	TEST UNIT READY
BD	MECHANISM STATUS
4A	GET EVENT STATUS NOTIFICATION
AD	READ DVD STRUCTURE
23	READ FORMATTED CAPACITIES
A4	REPORT KEY
A3	SEND KEY
A7	SET READ AHEAD
46	GET CONFIGURATION
AC	GET PERFORMANCE
51	READ DISC INFORMATION
52	READ TRACK/RZONE INFORMATION
A2	SEND EVENT

13. POWER MANAGEMENT SPECIFICATION

This drive has a power management function to reduce power consumption.

13.1 Power Management Modes

The drive has the following four power management modes. The transition between these modes is performed by the timer within the drive or a command issued by the host.

- Active mode
- Idle mode
- Standby mode
- Sleep mode

13.1.1 Transition in power management mode

The transition in the power management mode is shown in Fig. 13.1.1-1.

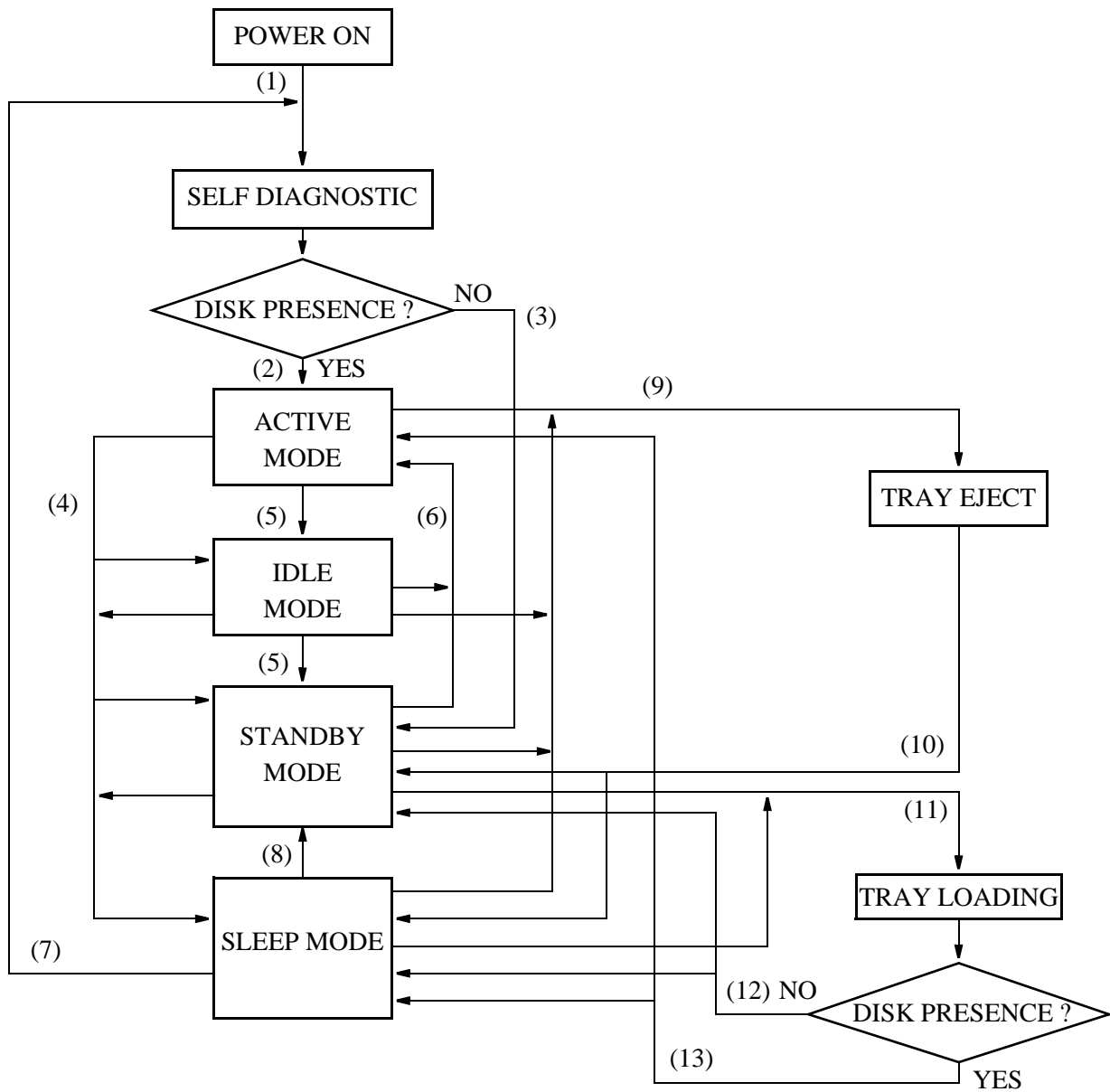

(Fig. 13.1.1-1) Transition in power management mode

- (1) When the RESET signal is released, the disc detection is performed after self-diagnostics are completed.
- (2) If the disc is loaded, the mode will switch to the active mode and starting operation will begin.
- (3) If the disc is not loaded, the mode will switch to the standby mode.
- (4) Using the power management command (IDLE, IDLE IMMEDIATE, STANDBY, STANDBY IMMEDIATE, SLEEP), the transition from the active mode to the idle, standby or sleep mode, from the idle mode to the standby or sleep mode, or from the standby mode to the idle or sleep mode is possible.
- (5) The transition from the active mode to the idle mode or from the idle mode to the standby mode is also performed by the timer the has. The timer will be initialized to the specified value when disc detection operation is under way or when a command which requires disc access is executed. The timer will not be initialized when a command which does not require disc access is executed in the active mode.
- (6) The resumption from the idle or standby mode to the active mode is initiated when a command which requires disc access is executed.
- (7) The resumption after the sleep mode is possible only after the RESET signal, the SRST (bit 2 of the DEVICE Control Register) or the ATAPI SOFT RESET command is detected. If resumption after the sleep mode is initiated using the RESET signal, an operation similar to when the power is switched ON occurs.
- (8) If resumption after the sleep mode is initiated using the SRST or the ATAPI SOFT RESET command, the drive enters the standby mode.
- (9) Tray ejection in each of the active, idle, standby and sleep modes is possible.
- (10) If the tray is ejected in the active, idle or standby mode, the drive enters the standby mode when the tray is out or the sleep mode when the tray is ejected in the sleep mode.
- (11) If the tray is inserted when the tray is out, the disc detection operation is performed.
- (12) If no disc is loaded, the drive will resume a mode when the tray is out.
- (13) If the disc is loaded, the drive will resume the active mode. However, the drive resumes the sleep mode following the TOC read only when the tray is ejected in the sleep mode.

13.2 Active Mode

A state in which the drive is capable of responding in the shortest possible time to an access using a command, and all the electrical circuitry of the drive, the pickup, spindle motor and sled motor are operating. In the following cases, the drive will enter the active mode:

- (1) While it is being booted after the power is switched ON and self diagnosis is under way.
- (2) While the booting operation or Reading of the TOC is under way when the tray is inserted and the disc is loaded.
- (3) While the booting operation or Reading of the TOC is in progress with the power ON and the disc loaded.
- (4) While an command that requires disc access is being executed.
- (5) Until the drive switches over to other power management mode using the timer in the drive or the command after either (2), (3) or (4) above is performed.

13.3 Idle Mode

The idle mode has the same operational functions as the active mode. However, the current consumption is reduced by lowering the rotational speed of the spindle motor in the idle mode.

The transition to the idle mode comes in the following two ways:

- (1) When using the timer in the drive:

After executing (2), (3) and (4) in 14.2, if the specified time elapses by the timer in the drive, the mode will switch from the active mode to the idle mode.

The specified time of the timer is set to 8 seconds.
- (2) When using the power management command (IDLE, IDLE IMMEDIATE):

The transition from the active or standby mode is possible using the power management command (IDLE, IDLE IMMEDIATE).

For details, refer to the Software Specification.

13.4 Standby Mode

Except for the functions required for the reception of a command, all other functions are in the power save condition. And although the command can be received, a time is required to restore the functions that are in the power save condition for the command that requires disc access. The transition to the standby mode comes in the following three ways:

- (1) When using the timer in the drive:

After executing (2), (3) and (4) in 13.2, if the specified time elapses by the timer in the drive, the mode will switch from the active to the standby mode via the idle mode.

Although the specified time of the timer can be preset using the STANDBY command or MODE SELECT command, it is set to 32 seconds by default. The transition time to the idle mode is included in the preset value of the timer.

For details, refer to the Software Specification. The timer will be initialized to the specified value after executing (2), (3) and (4) in 13.2. The timer will not be initialized when a command which does not require disc access is executed in the active mode.

- (2) When using the power management command (STANDBY, STANDBY IMMEDIATE) or START/STOP UNIT command:

The transition from the active or idle mode is possible using the power management command (STANDBY, STANDBY IMMEDIATE) or START/STOP UNIT command.

For details, refer to the Software Specification.

- (3) When the power is switched ON or a disc is not detected by the disc detection operation while the tray is being retracted, the drive will enter the standby mode.

13.5 Sleep Mode

The drive enters a state in which all functions are stopped and no command can be received.

The transition to the sleep mode is possible using the SLEEP command.

For details, refer to the Software Specification. The resumption from the sleep mode is possible using the RESET signal, the SRST (bit 2 of the Device Control Register) or the ATAPI SOFT RESET command.

13.5.1 Tray ejection/insertion in the sleep mode

If the eject button is pressed in sleep mode, the tray will be ejected before sleep mode is entered. If the tray is inserted while in this state, disc detection is performed; If the disc is loaded on the tray, the start-up operation is performed before sleep mode is entered. If the disc is not loaded on the tray, sleep mode is entered.

14. OTHERS

14.1 Using the Lens Cleaner

Some commercially available wet-type lens cleaners may sometimes actually make the lens dirtier rather than cleaning it. In general, we recommend that you avoid using a wet-type lens cleaner.

Use a dry-type lens cleaner.

14.2 RoHS Compliance

The drive complies with European directive "2002/95/EC".

14.3 Safety of Laser Products

When selling this unit or a system with this unit to an end user, print the following text in the instruction manual or enclose the separate sheet on which the following text is printed with the instruction manual.

This product has been designed and manufactured according to FDA regulations "title 21. CFR. chapter1, subchapter J. based on the radiation Control for Health and Safety Act of 1968", and is classified as a class 1 laser product. There is no hazardous invisible laser radiation during operation because invisible laser radiation emitted inside of this product is completely confined in the protective housings.

The label required in this regulation is shown bellow.

CAUTION
Use of controls or adjustments or performance of procedures other than those specified herein may result in hazardous radiation exposure.

Optical pickup	
Type	: TOP1100S
Manufacturer	: TopRay Technologies, Inc
Laser output	: Less than 0.5mW on the objective lens
Wavelength	: 770-800nm (CD) 645-662nm (DVD)
Standard	: IEC60825-1 : 2001

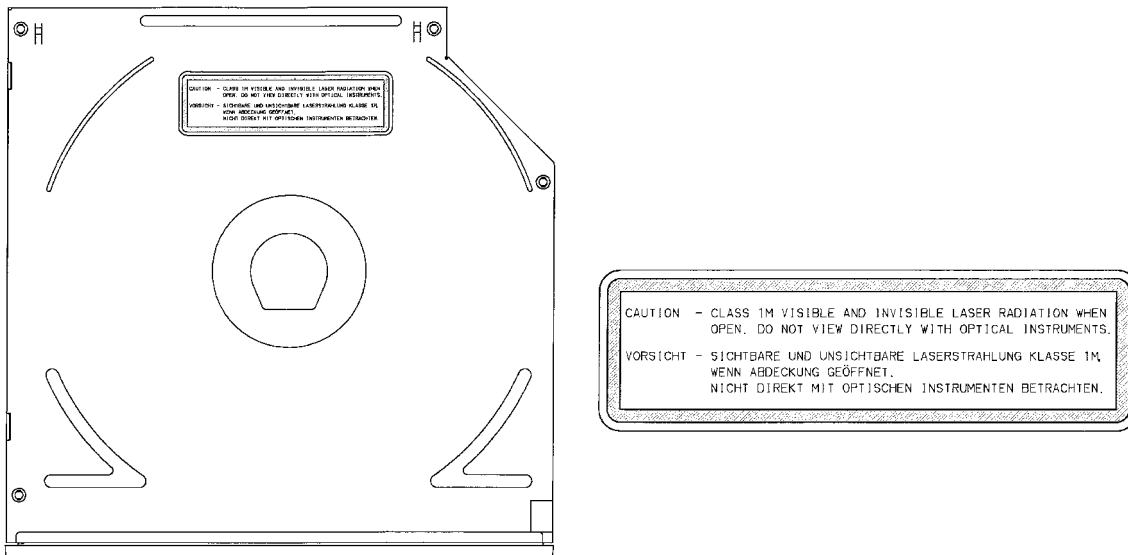

(Fig. 14.3-1)